

GC100

LEVEL INDICATING CONTROL PANEL



RELIABLE | SIMPLE | SAFE | SIDESLOPER® PUMPS ECONOMICAL FOR LEACHATE CONTROL

Sidesloper® Pumps

Manufactured by GunnCo Pumps & Control, Inc.

GC100

LEVEL INDICATING CONTROL PANEL



The *Sidesloper*® GC100 control panels are TRANSDUCER based design for SIDE SLOPE and VERTICAL wells and offers reliable and economical level indication, pump control, and safe operator access in a basic quality package.

- ▶ NEMA 4 Steel or 4x stainless steel
- ▶ Interior mounted operator controls
- ▶ User friendly level controller
- ▶ Intrinsically safe
- ▶ Large 30mm indicating lights and switches
- ▶ Elapsed hour meter standard
- ▶ Motor and control circuit breakers
- ▶ Phase sensitive motor overload
- ▶ Surge protected submersible transducer
- ▶ Continuous hinges and locking hasp door
- ▶ Operator safe
- ▶ Spare fuses and bulb provided
- ▶ LED high level alarm beacon
- ▶ Optional window
- ▶ UL rated
- ▶ Available in single phase 230 volt to 2 H.P.
- ▶ Available in three phase to 5 H.P.

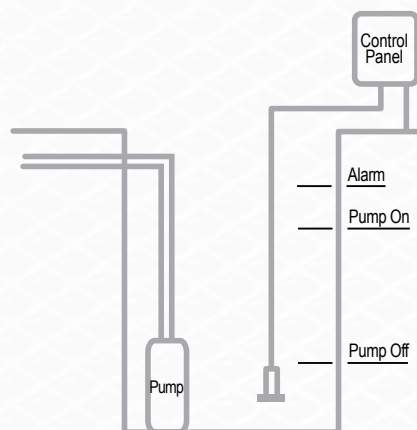
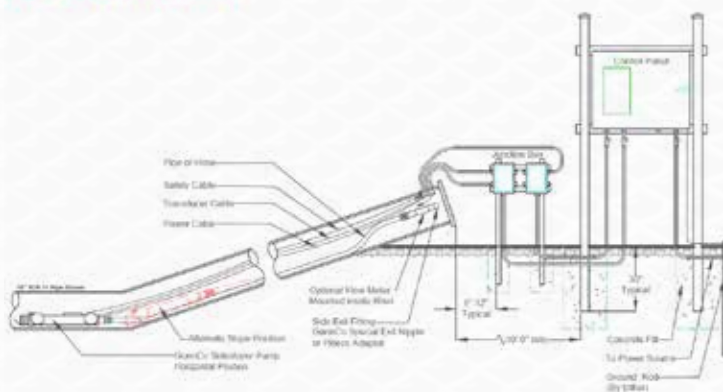

Distributed by:

Manufactured by:

GunnCo
Pump & Control, Inc.

770.889.7114

515 Industrial Way
Cumming, GA 30040
www.gunnco.com